

Stone Age Patio Series™ Fireplaces

Stone Age Patio Series fireplaces are perfect for applications where a simplified, block-friendly solution is required. Offering the quality, durability and performance advantages of the Stone Age fireplace, without the drawbacks of many similarly sized block or other non-certified fireplaces.

Outdoor applications only, 8' minimum clearance to combustibles required. Maximum of 4 additional feet of chimney may be added to these models.

Available with 24", 36" or 48" firebox opening width. Firebox opening height is 22", straight lintel only.

Item No	Model	Weight
SA-24PS	24" with Straight Lintel	1100
SA-36PS	36" with Straight Lintel	1500
SA-48PS	48" with Straight Lintel	1900



Refer to Section 3 of Price List

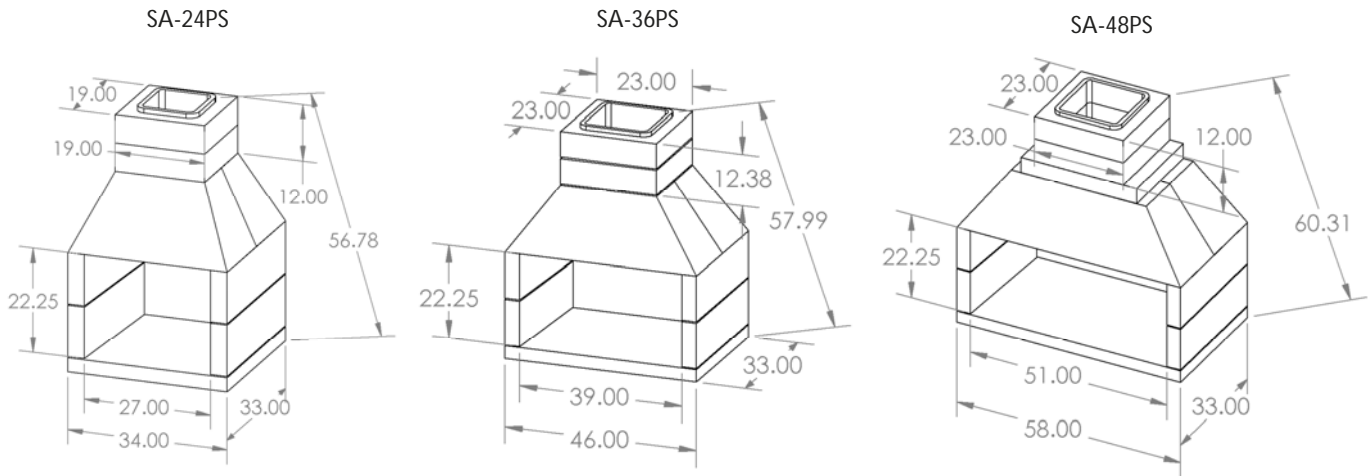

Accessory Items to Complete Installation of Patio Series Fireplaces

Item No	Model	Weight
Chimney Sections		
SAFL1313-6	6"t Small width for 24" Patio Series kits	100
SAFL1717-6	6"t Large for 36" - 48" Patio Series kits	100

Note: Chimney may be extended a maximum of 4 additional feet on Patio Series fireplaces.

Item No	Model	Weight
Firebrick		
SA-S1001	Firebrick - Splits, 9" x 4 1/2" x 1 1/4"	4

Note: Firebrick is optional and is not required on Patio Series Fireplaces.

Item No	Model	Weight
High-Temperature Mortar		
SA-APRM	Multi-Purpose Ready-Mix Mortar, 5 Gallons	60

Refer to Sections 8 and 19 of Price List

Recommended Accessories: Chimney cap, log grate.

SAFL1717-6



SA-S1001



SA-APRM

